



Combustion



Hybrid

# Explore our Technologies

## Permanently Engaged Starter Clutch with Dual Mass Flywheel Integration

for Passenger Cars and Commercial Vehicles

# Permanently Engaged Starter Clutch

The permanently engaged starter clutch (PES) is a dry one-way-clutch system in combination with a simplified starter, located between the internal combustion engine and the transmission. The main functions are the engine start and the physical starter disconnect. The biggest value added through the PES is its drag free operation at and above idle, while keeping a beneficial change of mind performance.

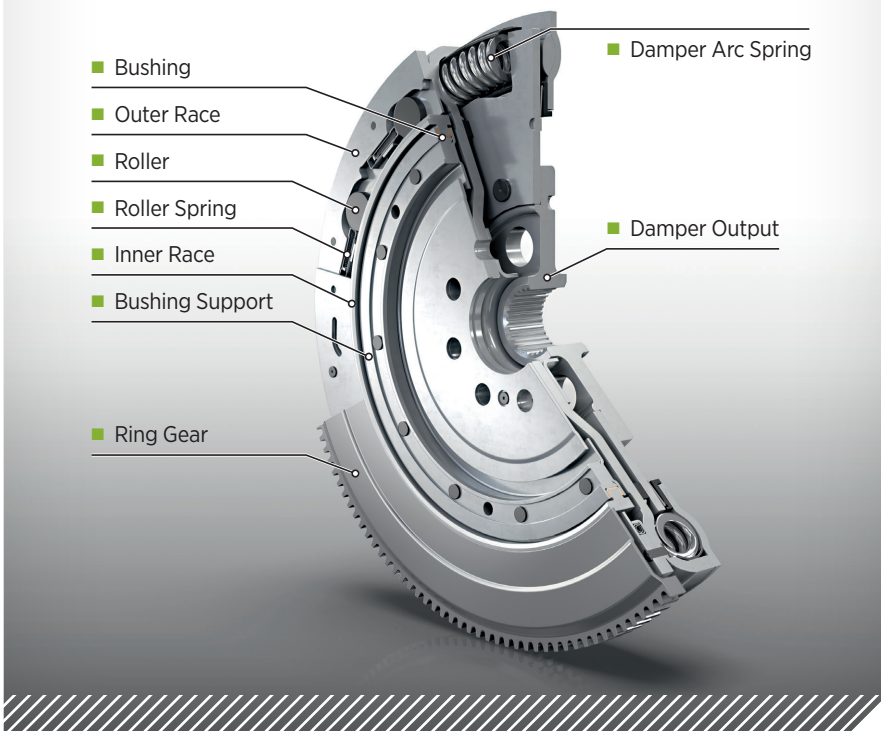

## Features

- Plug & Play system between ICE and transmission, bolted to crank shaft
- PES standalone with flex plate (shown on title page) or PES with dual mass flywheel integration (shown below)
- Torque converter connection also possible
- ICE start and drag free physical starter disconnect
- Advanced start/stop performance
- Short restart & change of mind
- No drag loss at idle speed and above

## Benefits

- NVH improvement in comparison to pinion starter
- Better fuel economy than a belt driven starting system (e. g. BSG)
- Enables beltless engines → axial space opportunity
- Additional axial space benefit due to integrated PES-DMF module
- No pinion engagement mechanism for starter needed

## Example integration layout

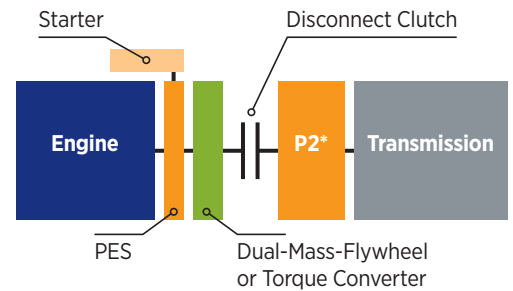

\*P2 E-Machine only shown as example hybrid architecture



Combustion



Hybrid

For Additional BorgWarner Information:  
[borgwarner.com](http://borgwarner.com)

 **BorgWarner**